

Classic Composition Mount | QMSC

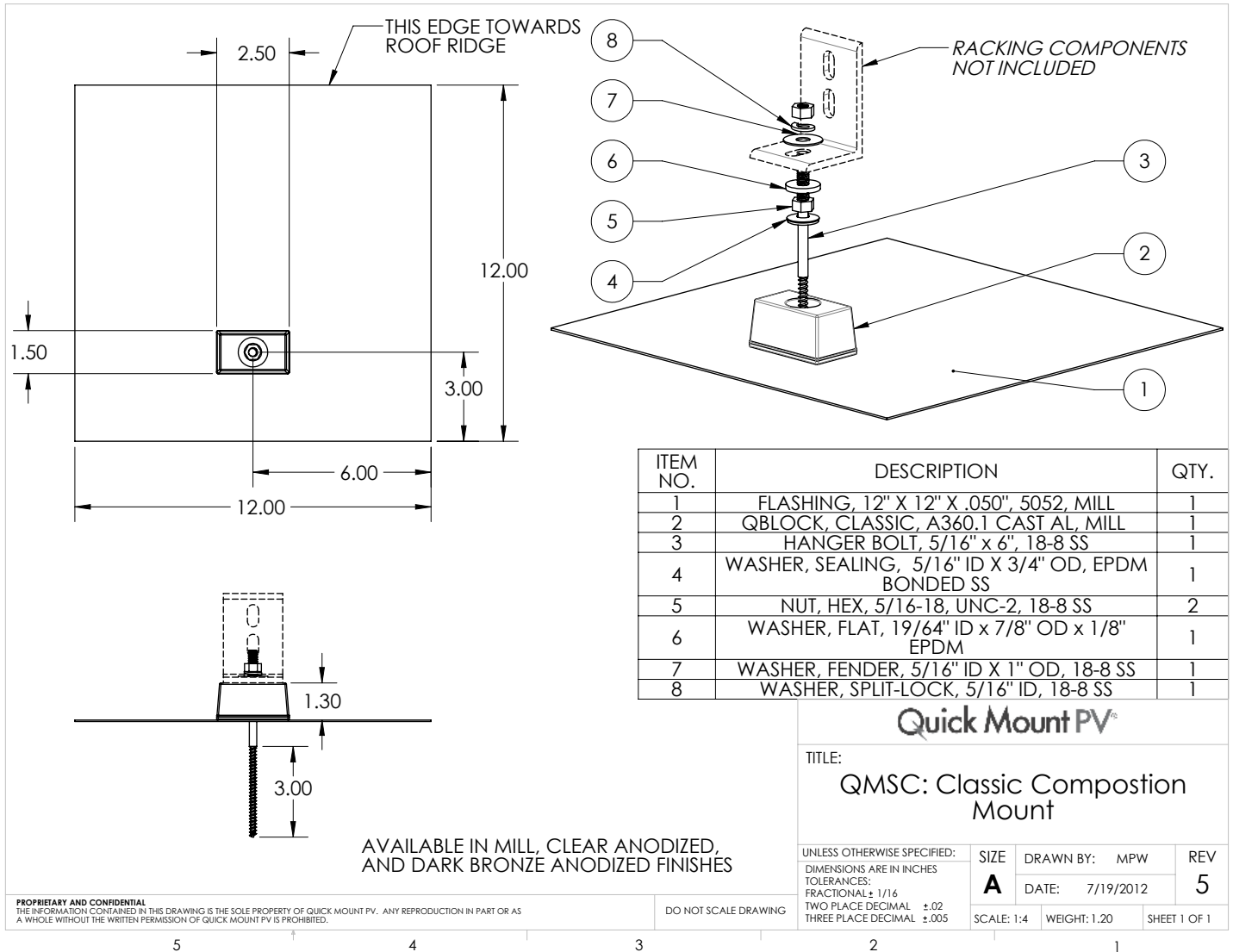

Lag pull-out (withdrawal) capacities (lbs) in typical lumber:

	Lag Bolt Specifications		
	Specific Gravity	5/16" shaft per 3" thread depth	5/16" shaft per 1" thread depth
Douglas Fir, Larch	.50	798	266
Douglas Fir, South	.46	705	235
Engelmann Spruce, Lodgepole Pine (MSR 1650 f & higher)	.46	705	235
Hem, Fir	.43	636	212
Hem, Fir (North)	.46	705	235
Southern Pine	.55	921	307
Spruce, Pine, Fir	.42	615	205
Spruce, Pine, Fir (E of 2 million psi and higher grades of MSR and MEL)	.50	798	266

Sources: American Wood Council, NDS 2005, Table 11.2 A, 11.3.2 A

- Notes:**
- 1) Thread must be embedded in a rafter or other structural roof member.
 - 2) See IBC for required edge distances.
- IMPORTANT:** To maintain waterproofing it is important that the aluminum flashing (item 1) is properly placed under one full course above the mounting block with at least 1/2" of the flashing extending up under an additional course above (3rd course). The bottom of the flashing should never overhang the shingle drip edge. See instructions on back.

Quick Mount PV®

Classic Composition Mounting Instructions

Installation Tools Required: tape measure, roofing bar, chalk line, stud finder, caulking gun, 1 tube of roof material compatible sealant, drill with 7/32" bit, drill or impact gun with 1/2" deep socket.

WARNING: Quick Mount PV products are NOT designed for and should NOT be used to anchor fall protection equipment.



1
Locate, choose, and mark centers of rafters to be mounted. Select the courses of roofing where Quick Mounts will be placed.



2
Carefully lift composition roof shingle with roofing bar, just above placement of Quick Mount.



3
Slide mount into desired position. Remove any nails that prevent getting the mount flush with front edge of shingle course. Mark center for drilling.



4
Using drill with 7/32" bit, drill pilot hole into roof and rafter, taking care to drill square to the roof. Do not use mount as a drill guide.

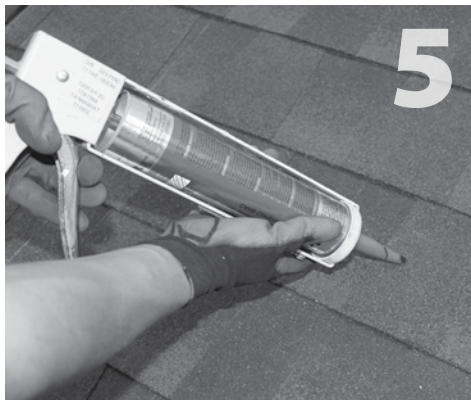

5
Clean off any sawdust, and fill hole with sealant compatible with roof material.



6
Slide mount back into position. Prepare hanger bolt with 1 hex nut and 1 sealing washer, insert through block into hole and drive hanger bolt into rafter, tightening to a solid snug fit. *



7
Insert EPDM rubber washer over hanger bolt into block.

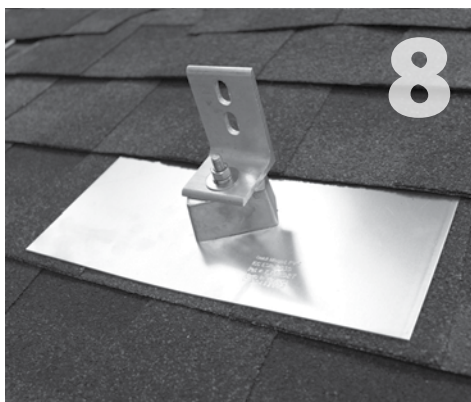

8
Using the rack kit hardware, secure the rack of your choice. Tighten to 13 foot pounds.

You are now ready for the rack of your choice. Follow all the directions of the rack manufacturer as well as the module manufacturer.

All roofing manufacturers' written instructions must also be followed by anyone modifying a roof system. Please consult the roof manufacturer's specs and instructions prior to touching the roof.

* It is not necessary or advisable to use nails or other fasteners to secure the perimeter of the flashing.